

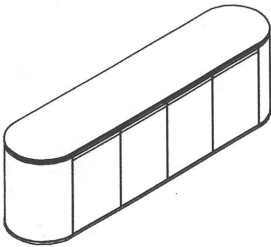

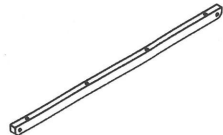

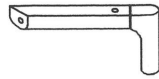

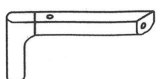

Assembly Instruction

INTE-SB200-01

 A: Sideboard x1	 B: Support bar x1	 D: Right Legs x2	 F: Sleeve nut M8*15mm x2
	 C: Left Legs x2	 E: Centre Legs x1	 C: Bolt M8*45mm x10
			 I: Spring Washer M8*14 x10
			 J: Flat Washer M8*16 x10
			 K: Allen key M4 x2

STEP 1

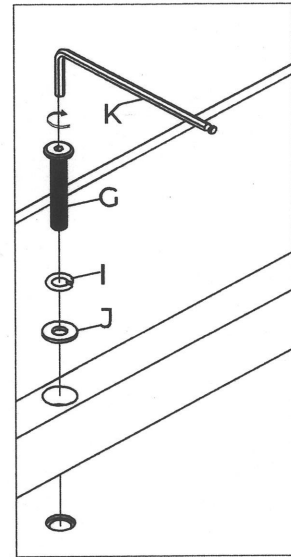
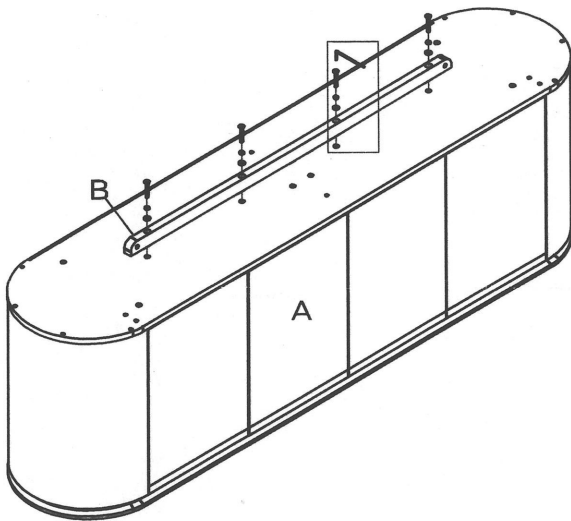

STEP 2

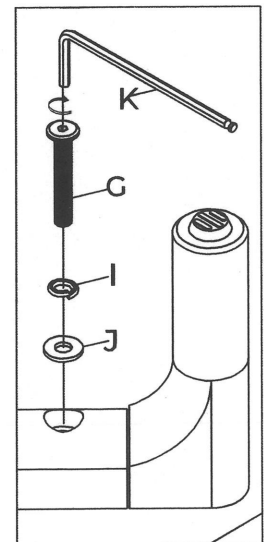
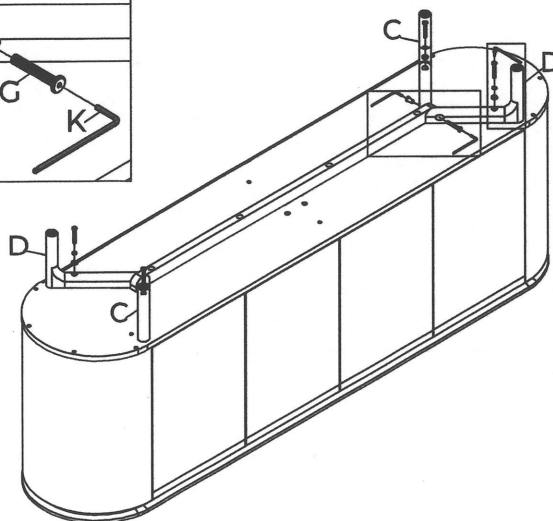
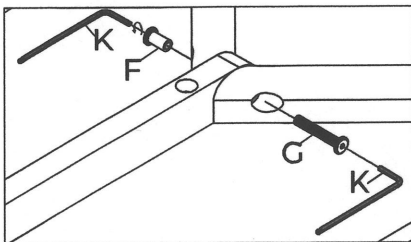

STEP 3

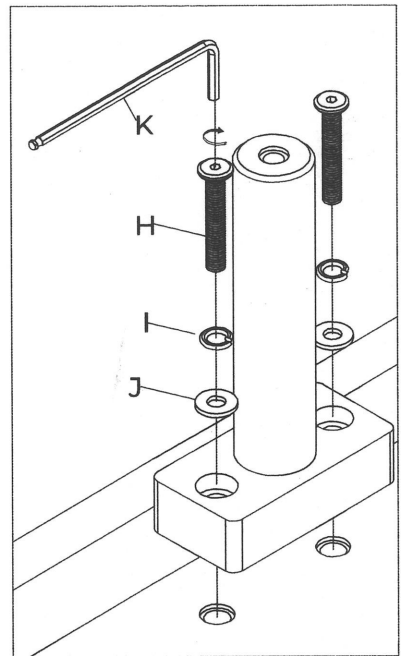
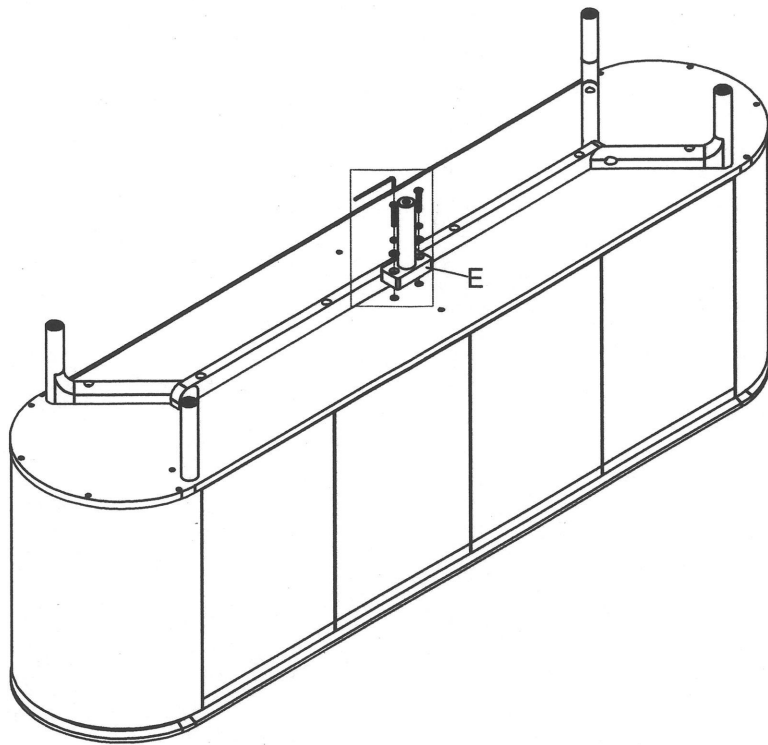

FINISH

